

**HP 8561A and HP 8562A/B
Portable Spectrum Analyzers
Operating and Programming Manual**



Operation and Programming Manual

HP 8561A and HP 8562A/B Portable Spectrum Analyzers

**COPYRIGHT © 1989 HEWLETT-PACKARD COMPANY
1212 VALLEY HOUSE DRIVE, ROHNERT PARK, CALIFORNIA 94928-4999, USA**

**Manual Part Number 08562-90086
Microfiche Part Number: 08562-90087**

Printed: July 1989

HP 8561A and HP 8562A/B Documentation Description

Manuals Shipped with Your Analyzer

Installation and Verification Manual

HP part number 08561-90003 (for HP 8561A)

HP part number 08562-90071 (for HP 8562A/B)

- Tells you how to install the spectrum analyzer.
- Tells you how to verify spectrum analyzer performance.
- Tells you what to do in case of a failure.

Operation and Programming Manual

HP part number 08562-90086

- Describes analyzer features.
- Tells you how to make measurements with your spectrum analyzer.
- Tells you how to program your spectrum analyzer.

Quick Reference Guide

HP part number 08562-90006

- Provides you with a listing of all remote programming commands.

Options

Service Manual (part of Option 915)

HP part number 08562-90062

- Describes troubleshooting and adjustments of the analyzer.

DETECTOR SAMPLE	2-50
DETECTOR POS PEAK	2-51
DETECTOR NEG PEAK	2-51
PREV MENU	2-51
FFT	2-51
PREV MENU	2-52
TRIG	2-53
CONT	2-53
SINGLE	2-53
FREE RUN	2-53
VIDEO	2-53
LINE	2-53
EXTERNAL	2-53
DISPLAY	2-54
PRINT PLOT	2-54
PRINT	2-54
COLOR PRINT	2-54
PLOT	2-54
PLOT OPTIONS	2-55
PLOT TRACE A	2-55
PLOT TRACE B	2-55
PLOT GRATICUL	2-55
PLOT ANNOT	2-55
PLOT ORG DSP GRAT	2-55
PREV MENU	2-55
PREV MENU	2-55
DISPLAY LINE and DSP LINE ON OFF	2-56
THRESHLD and THRESHLD ON OFF	2-56
MORE	2-56
SCREEN TITLE	2-56
SELECT CHAR	2-56
SPACE	2-56
BACK SPACE	2-56
TITLE DONE	2-56
CHAR SET 1 2	2-56
ERASE TITLE	2-57
GRAT ON OFF	2-57
ANNOT ON OFF	2-57
FREQ DSP OFF	2-57
FOCUS	2-57

INTEN	2-57
Trace Math in the Analyzer	2-58
Adding and Subtracting in dBm	2-58
Use A-B+DL→A to Correct Data	2-58
Adding and Subtracting in Volts	2-59
Trace Data Limits	2-59
Marker Priority	2-61
3. Common Measurements	
Demodulate and Listen with Keys	3-2
Third-Order Intermodulation Distortion	3-4
What Is Intermodulation Distortion?	3-4
The Functions Used	3-4
Measurement Overview	3-4
Stepping through the Measurement	3-5
Harmonic Distortion	3-10
Why Measure Harmonic Distortion?	3-10
The Functions Used	3-10
“Fast Measurement” Overview	3-10
Making Fast Harmonic Measurements	3-10
Getting the Most Accurate Harmonic Distortion Measurements	3-13
Percent of Harmonic Distortion	3-14
Resolution Bandwidth	3-16
Input Signals of Equal Amplitude	3-16
Input Signals of Unequal Amplitude	3-17
Amplitude Modulation	3-20
Frequency Modulation	3-22
Pulsed RF	3-27
Pulse Mode	3-27
Center Frequency, Sidelobe Ratio, and Pulse Width	3-28
Pulse Repetition Frequency (PRF)	3-30
Peak Pulse Power and Desensitization	3-31
External Harmonic Mixers and Signal Identification	3-33
Equipment Setup	3-33
Conversion Loss	3-34
Signal Identification	3-34
Bias	3-37
4. Programming Fundamentals	
Remote Operation	4-1
Connecting the Analyzer to the Computer	4-1
Setting the Address	4-2
How to Program Common Spectrum Analyzer Functions	4-3
Example 1	4-3
Example 2	4-3
Example 3	4-4
Developing a Simple Program	4-4
Example 4	4-5
Example 5	4-5
Example 6	4-5
Example 7	4-6

Reading Marker Frequency and Amplitude	4-6
Example 8	4-6
Creating Screen Titles	4-7
No-Format Method	4-8
Example 9	4-8
Format Methods	4-8
Making a Title in A-Block Format	4-8
Example 10	4-8
Example 11	4-8
Making a Title in I-Block Format	4-9
Example 12	4-9
Generating Plots Remotely	4-10
Plotter Requirements	4-10
Making a Basic Plot	4-11
Example 13	4-11
Example 14	4-12
Plotting Options	4-12
Example 15	4-12
Trace Data Transfers	4-14
Transfer Requirements	4-14
Trace Length	4-14
Trace conditions	4-14
Example 16	4-14
Example 17	4-14
Specify the Data Format Before Transferring Data	4-15
Formats	4-15
P-Format	4-15
Example 18	4-15
Example 19	4-16
B-Format (output only)	4-16
Example 20	4-17
Example 21	4-17
A-Block Format	4-18
Example 22	4-18
Example 23	4-19
I-Block Format	4-19
Example 24	4-20
Example 25	4-20
M-Format (output only)	4-20
Example 26	4-21
Service Requests	4-22
The Status Register	4-22
Masking Service Requests	4-23
Computer Interrupt Statements	4-23
Example 27	4-24
Reading Service Request Data	4-24
Example 28	4-24
Reading Service Requests from More Than One Instrument	4-25
Example 29	4-25
Testing Service Request Routines	4-26
Example 30	4-26

Trace Math	4-27
Adding and Subtracting in dBm	4-27
Use AMBPL to Correct Data	4-27
Example 31	4-28
Adding and Subtracting in Volts	4-28
Example 32	4-28
Trace Data Limits	4-29
Input and Output Buffers	4-30
Benefits of an Output Buffer	4-30
Example 33	4-30
Example 34	4-31
Buffer Space	4-31
Preventing Timeouts	4-31
Synchronizing Your Program	4-32
Clearing the Buffers	4-32
Illustrating Programming Techniques	4-33
Percent of Harmonic Distortion	4-33
Harmonic Distortion Program	4-33
Program Annotation	4-34
5. Language Reference	
Syntax Conventions	5-2
Command Summary	5-6
A. Softkey Cross Reference	
B. Programming Commands vs. Front-Panel Key	
C. HP-IB Errors	
D. Backward-Compatible Commands	
E. Simplified Block Diagram	

Index

Figures

1-1. HP 8562A Front Panel	1-2
1-2. Display Annotation	1-4
1-3. HP 8562A/B Rear Panel	1-6
1-4. Frequency Key Menu	1-8
1-5. Center Frequency Set to 300 MHz	1-9
1-6. Frequency Span Reduced to 20 MHz	1-10
1-7. Signal Peak Set to Reference Level	1-11
1-8. Activated Normal Marker	1-12
1-9. Frequency, Span, and Amplitude Set for Calibration	1-13
1-10. Signal Peak Calibrated to the Reference Level	1-14
2-1. Fundamental Functions	2-2
2-2. FREQUENCY Menu	2-2
2-3. SPAN Menu	2-5
2-4. AMPLITUDE Menu	2-7
2-5. Marker Functions	2-12
2-6. Marker ON Menu	2-12
2-7. PEAK SEARCH Menu	2-15
2-8. PEAK EXCURSN Defines the Peaks on a Trace	2-17
2-9. MKR → Menu	2-19
2-10. Instrument State Functions	2-21
2-11. PRESET Menu	2-21
2-12. FREQ COUNT Menu	2-25
2-13. DEMOD Menu	2-27
2-14. SAVE Menu	2-30
2-15. RECALL Menu	2-32
2-16. CRT Alignment Pattern	2-35
2-17. MIXER INT Menu	2-36
2-18. MIXER EXT Menu	2-38
2-19. Control Functions	2-43
2-20. SWEEP Menu	2-43
2-21. AUTO COUPLE Menu	2-45
2-22. BW Menu	2-46
2-23. TRACE Menu	2-48
2-24. TRIG Menu	2-53
2-25. DISPLAY Menu	2-54
2-26. Display Units	2-60
3-1. Spectrum Analyzer Tuned to Sweep the FM Band	3-2
3-2. Marker Placed on a Signal to be Demodulated	3-3
3-3. Two Input Signals and Resulting Intermodulation Distortion	3-4
3-4. Third-Order Intermodulation Test Setup	3-5
3-5. Signals Centered on Display	3-6
3-6. Signal Peak Set to the Reference Level	3-7

3-7. Intermodulation Distortion Measured in dBc	3-8
3-8. Display with Title	3-9
3-9. RECALL Menu	3-9
3-10. Input Signal and Harmonics	3-11
3-11. Harmonic Distortion Measured in dBc	3-12
3-12. Percent of Distortion Versus Harmonic Amplitude	3-12
3-13. Input Signal Displayed in a 15 MHz Span	3-13
3-14. Second Harmonic Displayed in dBc	3-14
3-15. 1 kHz Signal Separation	3-16
3-16. 2 kHz Signal Separation	3-17
3-17. Bandwidth Shape Factor	3-17
3-18. 100 kHz Bandwidth Resolution	3-18
3-19. 300 kHz Bandwidth Resolution	3-19
3-20. An Amplitude-Modulated Signal	3-20
3-21. Percentage of Modulation	3-21
3-22. A Frequency-Modulated Signal	3-22
3-23. FM Signal with Carrier at a Null	3-23
3-24. FM Signal with First Sidebands at a Null	3-23
3-25. Bessel Functions for Determining Modulation Index	3-24
3-26. FM Deviation Test Setup	3-25
3-27. Markers Show Modulating Frequency	3-26
3-28. Main Lobe and Side Lobes	3-27
3-29. Trace Displayed as a Solid Line	3-28
3-30. Center Frequency at Center of Main Lobe	3-28
3-31. Markers Show Sidelobe Ratio	3-29
3-32. Markers Show Pulse Width	3-30
3-33. Measuring Pulse Repetition Frequency	3-31
3-34. External Mixer Setup (a) without Bias; (b) with Bias	3-33
3-35. Signal Responses Produced of a 50 GHz Signal in U Band	3-35
3-36. Response for Valid Signals	3-36
3-37. Response for Invalid Signals	3-36
4-1. Connecting Analyzer to an HP 9000 Series 300 Computer	4-2
4-2. Address Displayed on the Screen	4-2
4-3. Screen Titles	4-7
4-4. Plotter Address Set to 5	4-10
4-5. P1 and P2 Coordinates	4-10
4-6. Measurement Units	4-21
4-7. Display Units	4-29
4-8. Buffer Summary	4-30
5-1. Command Syntax	5-2
5-2. CRT Alignment Pattern	5-13
5-3. MKPX Determines Which Signals are Considered Peaks	5-103
E-1. Simplified Block Diagram	E-1

Tables

1-1. Front-Panel Connector Data	1-3
2-1. Frequency Bands and Their Minimum Reference Levels	2-8
2-2. State of Instrument After PRESET is Executed	2-22
2-3. Mixing Harmonics for Frequencies above 18 GHz	2-39
2-4. Conversion Losses for Frequencies above 18 GHz	2-40
3-1. Carrier Nulls and Modulation Indexes	3-24
3-2. Sideband Nulls and Modulation Indexes	3-24
3-3. External Mixer Frequency Ranges	3-34
4-1. Scaling Points for Various Plotters	4-11
4-2. HP 8562A/B Status Register	4-22
5-1. Characters and Secondary Keywords (Reserved Words)	5-3
5-2. Syntax Elements	5-5
5-3. Status Byte Definition	5-9
5-4. External-Mixer Frequency Bands	5-65
5-5. Frequency Bands and the Corresponding LO Harmonic	5-70
5-6. Preset State	5-76
5-7. Frequency Ranges and Minimum Reference Level	5-131
5-8. HP 8562A/B Service Requests	5-136
5-9. Special Printing Characters	5-159
A-1. Softkey Cross Reference	A-1
B-1. Commands vs. Keys	B-1
C-1. Error Codes	C-1

Overview

This chapter introduces the front- and rear-panel keys and connectors on the HP 8561A and HP 8562A/B Spectrum Analyzers. Complete descriptions of each front-panel function appear in Chapter 2. The following topics are discussed:

The Front Panel	1-2
Display Annotation	1-4
The Rear Panel	1-6
Introducing Menus and Keys	1-8
Making a Basic Measurement	1-9
Calibrating the Spectrum Analyzer	1-13
Key Menus	1-15

Chapter 2 describes the functions available from the front panel.

Chapter 3 provides examples of common measurements using the spectrum analyzer.

Chapter 4 documents programming techniques and examples.

Chapter 5 documents each spectrum analyzer programming command.

Appendixes provides additional information and references.

Note



In this manual the frequency range of HP 8562A/B instruments is listed as 9 kHz to 22 GHz. However, the frequency range of HP 8562A/B instruments serial prefixed below 2929A is 1 kHz to 22 GHz.

VTL

Video Trigger Level

Syntax

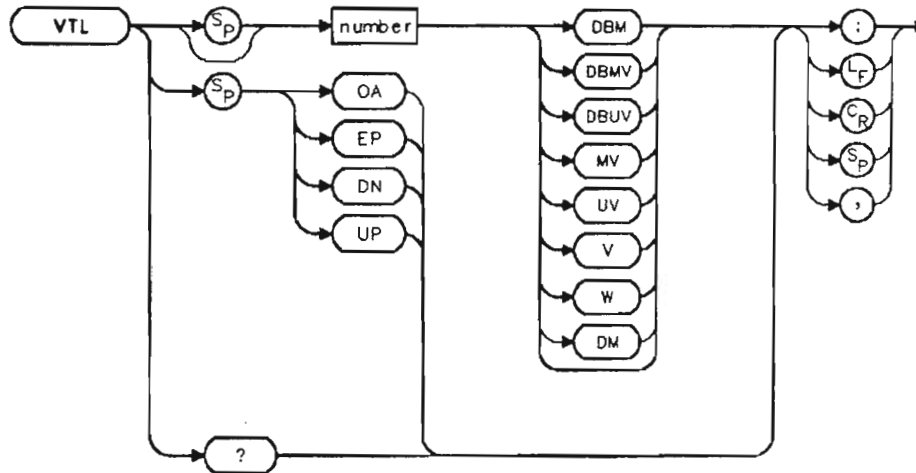

Item	Description/Default	Range
number	real	-220 to 30

UP/DN: increments by 1 vertical division.

Example

```

10 OUTPUT 718;"TM VID;"
20 OUTPUT 718;"VTL -20DBM;"
30 END

```

Description

The VTL commands sets the video trigger level when the trigger mode is set to VIDEO (refer to the TM command). A dashed line appears on the display to indicate the level. The default value is 0 dBm.

Softkey Cross Reference

Use this appendix to locate a softkey. For each softkey listed, a corresponding front panel key is listed. Pressing this key presents the menu containing the desired softkey.

Table A-1. Softkey Cross Reference

Softkey	Hardkey
0→10V LO SWP	(SWEEP)
.5 V/GHz (FAV)	(SWEEP)
10 MHz IN EXT	(FREQUENCY)
99% POWER BW	(ON)
A	
ADJCURR IF STATE	(AMPLITUDE)
A EXCH B	(TRACE)
AGC ON OFF	(DEMOD)
ALL	(AUTO COUPLE)
AH DEMOD ON OFF	(DEMOD)
AMPTD CORRECT	(EXT)
ANNOT ON OFF	(DISPLAY)
ATTEN	(AMPLITUDE)
ATTEN AUTO MAN	(AMPLITUDE)
AVERAGE CWV LOSS	(EXT)
A+B→A	(TRACE)
A-B→A ON OFF	(TRACE)
A-B+DL→A ON OFF	(TRACE)

Programming Commands vs. Front-Panel Key

Table B-1. Commands vs. Keys

Command	Name	Key
ADJALL	Execute Turn-on Adjustments	
ADJCRT	CRT Adjustment Pattern	CRT ADJ PATTERN
ADJIF	Execute IF Adjustments	FULL IF ADJ
AMB	Trace A Minus Trace B	A-B→A ON OFF
AMBPL	Trace A Minus Trace B Plus Display Line	A-B+DL→A ON OFF
ANNOT	Annotation On/Off	ANNOT ON OFF
APB	Trace A Plus Trace B	A+B→A
AT	Input Attenuator	ATTEN ATTEN AUTO MAN
AUNITS	Absolute Amplitude Units	UNITS
AUTOCP	Autocouple All "AUTO" Functions	ALL
AXB	Trace A Exchange Trace B	A EXCH B
BLANK	Blank Trace	BLANK A BLANK B
BML	Trace A Minus Display Line	B-DL→B
CF	Center Frequency	FREQUENCY CENTER FREQ
CLRW	Clear/Write Trace	CLR-WRT A CLR-WRT B
CNVLOSS	External Mixer Conversion Loss	CNV LOSS VS FREQ
CONTS	Continuous Sweep	CONT
COUPLE	HP 8561A. Couple ac or dc input	COUPLING AC DC
DEMODO	Demodulation	AM DEMOD ON OFF FM DEMOD ON OFF
DEMODAGC	Demodulation Automatic Gain Control	
DEMODT	Demodulation Time	DEMOD TIME
DET	Detection Mode	DETECTOR MODES
DL	Display Line	DISP LIN ON OFF
DONE	Done	

Table C-1. Error Codes (continued)

Error Code	Error	Probable Cause
130	BAD TDF	Arguments are valid only for the TDF command
131	?? AM/FM	AM/FM are not valid arguments for the command
132	!FAV/RMP	FAV/RAMP are not valid arguments for the command
133	!INT/EXT	ENT/EXT are not valid arguments for the command
134	??? ZERO	ZERO is not a valid argument for the command
135	??? CURR	CURR is not a valid argument for the command
136	??? FULL	FULL is not a valid argument for the command
137	??? LAST	LAST is not a valid arguent for the command
138	!GRT/DSP	GRT/DDSP is not a valid argument for the command
139	PLOTONLY	Use argument only with the PLOT command
140	??PWRON	PWRON is not a valid argument for the command
141	BAD ARG	Argument is valid only for the FDIAG command
142	BAD ARG	Query is expected for the FDIAG command
143	NO PRESL	Preselector hardware is required
144	NEXT 44	Next error space

Backward-Compatible Commands

The following list of commands are used by the HP 8566A and HP 8568A spectrum analyzers and are recognized by the HP 8561A and HP 8562A/B. This allows the HP 8561A and HP 8562A/B to use programs written for these Hewlett-Packard spectrum analyzers with only minor modifications. It is recommended that only the HP 8561A and HP 8562A/B commands be used when writing new programs.

Backward-Compatible Commands

Old Command	HP 8561A and HP 8562A/B Command	Description
A1	CLRW TRA	Clear-Write Trace A
A2	MXMH TRA	Maximum Hold Trace A
A3	VIEW TRA	Store-View Trace A
A4	BLANK TRA	Blank Trace A
B1	CLRW TRB	Clear-Write Trace B
B2	MXMH TRB	Maximum Hold Trace B
B3	VIEW TRB	Store-View Trace B
B4	BLANK TRB	Blank Trace B
BL	BML	Trace B minus Display Line
C1	AMB OFF	Trace A minus Trace B off
C2	AMB ON	Trace A minus Trace B on
CA	AT AUTO	Couples the RF attenuator
CR	RB AUTO	Couples the resolution bandwidth
CS	SS AUTO	Couples the center frequency step size
CT	ST AUTO	Couples the sweep time
CV	VB AUTO	Couples the video bandwidth
E1	MKPK HI	Marker to highest peak
E2	MKCF	Marker to Center Frequency
E3	MKSS	Marker Frequency to Center Frequency Step Size
E4	MKRL	Marker to Reference Level
EX	AXB	Exchange Trace A and Trace B
GZ	GHZ	Gigahertz (unit)
KZ	KHZ	Kilohertz (unit)
L0	DL OFF	Display Line off
LB	TEXT	Write text to display
M1	MKOFF	Marker off
M2	MKN	Marker Normal on
M3	MKD	Marker Delta on

Simplified Block Diagram

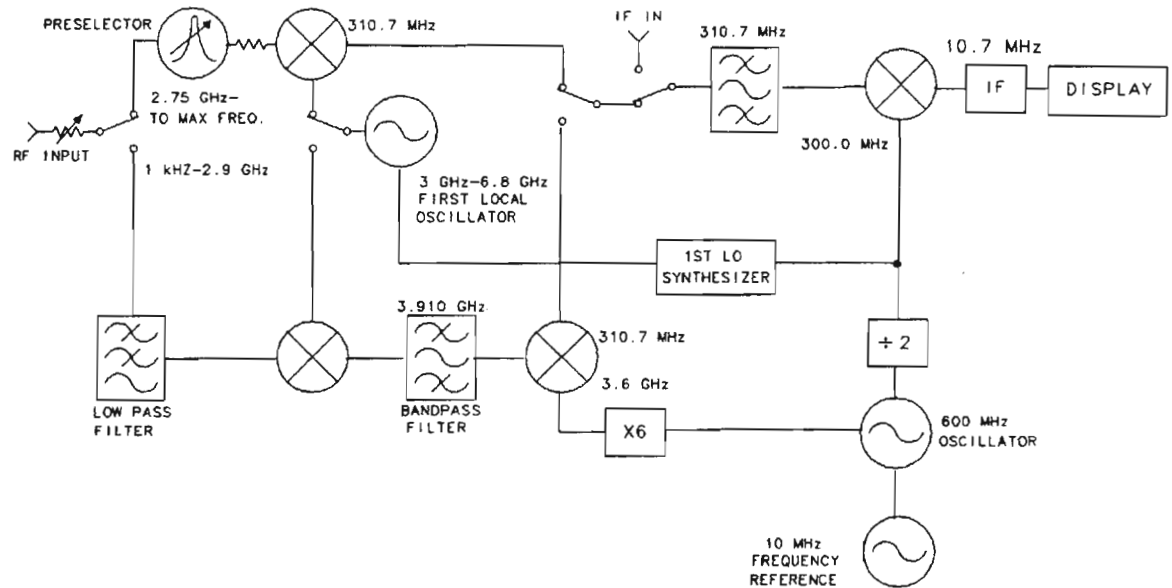

Figure E-1. Simplified Block Diagram

Index

A

A

- annotation, 1-5
 - frequency band, 3-34
- A-block format, 4-8
- A+B→A
 - example, 2-58
 - menu key, 2-50
- absolute amplitude units, 5-24
- ADJALL command, 5-11
- ADJCRT command, 5-12
- ADJ CURR IF STATE menu key, 2-10
- ADJIF command, 5-14
- adjust CRT alignment, 5-12
- adjust IF, 5-14
- A EXCH B menu key, 2-50
- AGC ON OFF menu key, 2-29
- ALL menu key, 2-45
- AMB command, 5-16
- AMBPL, 4-27
- AMBPL command, 5-18
- A-B+DL→A
 - example, 2-58
 - menu key, 2-49
- A-B→A
 - example, 2-58
 - menu key, 2-49
- amplitude, 1-2
- AMPLITUDE
 - key, 2-7
 - menu, 1-15
- amplitude control, 5-6
- amplitude modulation, 3-20
- AMPTD CORRECT menu key, 2-39
- ANNOT
 - command, 5-20
 - menu key, 2-57
- annotation, 5-20
 - +, 2-42
 - A, 2-9
- ACTIVATE TRACE, 2-40
- blank annotation, 2-57
- blank frequency, 2-57
- blank graticule, 2-57
- D, 2-50
- F, 2-4

K, 2-13

LOST SIGNAL, 2-40

M, 2-49

-, 2-42

NOT FOUND, 2-40

R, 2-9

S, 2-44

T, 2-53

APB, 4-28

APB command, 5-21

AT command, 5-22

ATTEN menu key, 2-8

AUNITS command, 5-24

AUTO COUPLE

key, 2-45

menu, 1-15

auto coupled, 5-26

AUTOCPPL command, 5-26

AVERAGE CNV LOSS menu key, 2-39

AXB command, 5-27

B

bandwidth control, 5-6

BIAS

caution, 2-42

menu key, 2-42

NEGATIVE menu key, 2-42

note, 2-42

OFF menu key, 2-42

POSITIVE menu key, 2-42

bias current, 3-37

bias voltage, 3-37

BLANK

command, 5-28

trace A menu key, 2-48

trace B menu key, 2-49

B-DL→B menu key, 2-50

BML command, 5-29

buffers, 4-30

clearing, 4-32

preventing timeouts, 4-31

space, 4-31

synchronizing, 4-32

BW menu, 1-15

BW key, 2-46

C

- cable
 - SMA, 3-33
- calibration
 - reference level, 1-13
- caution
 - bias, 2-42
 - maximum input level, 1-3
 - maximum input signal, 2-8
 - mixer LO power, 3-33
 - voltage selection, 1-6
- CENTER FREQ menu key, 2-3, 2-28
- center frequency, 5-30
 - step size, 2-20, 5-148
- CF command, 5-30
- CF STEP menu key, 2-3
- character sets, 2-56
- CHAR SET 1 2 menu key, 2-56
- CLEAR, 4-32
- clear write, 5-32
- CLRW command, 5-32
- CLR-WRT A menu key, 2-48
- CLR-WRT B menu key, 2-48
- CNVLOSS command, 5-33
- CNV LOSS VS FREQ menu key, 2-39
- COLOR PRINT menu key, 2-54
- Command Mnemonic, 5-2
- Command Terminators, 5-2
- compression, 2-45
- computer interrupt, 4-23
- CONT menu key, 2-43, 2-53
- control, 1-2
- control functions, 2-43
- CONTS command, 5-35
- conversion loss, 2-39, 3-37, 5-33
- COUNTER
 - menu key, 2-25
 - RES menu key, 2-25
- COUPLE command, 5-36
- COUPLING AC DC menu key, 2-11
- coupling control, 5-6
- CRT ADJ PATTERN menu key, 2-34

D

D

- annotation, 1-5
- frequency band, 3-34
- data keys, 1-2
- dB μ V menu key, 2-10
- dBm menu key, 2-10
- dBmV menu key, 2-10
- dc coupling, 2-11, 5-36
- demod
 - example, 3-2

DEMODO

- AM menu key, 2-27
- FM menu key, 2-27
 - key, 2-27
 - menu, 1-16
 - TIME menu key, 2-29
- DEMODOAGC command, 5-40
- DEMODO command, 5-38
- DEMODO command, 5-42
- demodulation, 5-6, 5-38
 - AM, 3-2
 - automatic gain control, 5-40
 - example, 3-2
 - FM, 3-2
 - time, 5-42
- DET command, 5-44
- detector
 - modes, 5-44
 - positive peak, 2-48
 - sample, 2-46
- DETECTOR
 - NEG PEAK menu key, 2-51
 - NORMAL menu key, 2-50
 - POS PEAK menu key, 2-51
 - SAMPLE menu key, 2-50
- DISPLAY menu, 1-16
- display annotation, 1-4
- display control, 5-7
- DISPLAY key, 2-54
- display line, 5-46
- DISPLAY LINE menu key, 2-56
- display units, 2-59
- distortion products, 3-6
- DL command, 5-46
- DONE
 - command, 5-48
 - command with TS, 4-32
- Dotted Lines, 5-2
- DSP LINE ON OFF menu key, 2-56
- DSPL LIN ON OFF menu key, 2-49
- dynamic range, 2-9, 2-45, 3-7

E

- E, 3-34
- earphone jack, 1-6
- elapsed time, 5-51
- ELAPSED TIME menu key, 2-35
- end or identify, 4-9, 4-30
- ENTER statement, 4-6, 4-30
- ERASE TITLE menu key, 2-57
- ERR command, 5-49
- error, 5-49
- ET command, 5-51
- EXT, 3-33
 - menu, 1-17

EXTERNAL menu key, 2-53

external mixer

- bias, 5-81, 3-37
- commands, 5-7
- mode, 5-112
- conversion loss, 3-34, 3-37
- equipment, 3-33
- frequency bands, 3-33, 3-37
- signal identification, 3-34
- using, 3-33
- valid signals, 3-35

EXT key, 2-38

F

F

- annotation, 1-5
- frequency band, 3-34

FA command, 5-52

FACTORY PRESEL PK menu key, 2-35

fast Fourier transform, 5-59

FB command, 5-54

FDIAG command, 5-56

FDSP command, 5-58

FFT command, 5-59

FFT menu key, 2-51

focus, 2-57

FOCUS menu key, 2-57

FOFFSET command, 5-61

Fourier transform, 2-51

FREE RUN menu key, 2-53

FREF command, 5-63

FREQ COUNT menu, 1-17

FREQ COUNT key, 2-25

FREQ DIAGNOSE menu key, 2-33

FREQ DSP OFF menu key, 2-57

FREQ OFFSET menu key, 2-4

frequency, 1-2

- band, 2-38
- band overlap, 1-10
- band switching, 2-7
- center step, 2-3
- control, 5-7
- counter, 5-90
- counter resolution, 5-91
- diagnostics, 5-56
- display off, 5-58
- external mixing, 3-33
- modulation Bessel null, 3-24
- modulation carrier nulls, 3-24
- modulation deviation, 3-25
- modulation FM with incidental AM, 3-26
- modulation measurement, 3-22
- modulation sideband nulls, 3-24
- offset, 2-4, 5-61
- range, 1-1
- reference, 2-33, 5-63
- shift, 3-35
- span, 2-5, 5-143

FREQUENCY

- key, 2-2
- menu, 1-17

front panel, 1-2

front-panel keys, 1-2

FS command, 5-64

FULBAND command, 5-65

full band, 5-65

FULL BAND menu key, 2-38

FULL IF ADJ menu key, 2-10

full span, 5-64

fundamental functions, 2-2

G

G, 3-34

GRAT command, 5-67

graticule, 5-67

GRAT ON OFF menu key, 2-57

H

harmonic distortion

- definition, 3-10
- measurement, 3-10, 3-13
- percentage of, 3-14
- program example, 4-33

harmonic

- band, 3-34
- lock, 5-69
- tuning to, 2-3
- unlock, 5-71

HD command, 5-68

HNLOCK command, 5-69

HNUNLK command, 5-71

hold, 5-68

HP-IB

- address, 4-2
- connection, 4-1
- connector, 1-6

HP-IB address

- analyzer, 2-21, 2-24
- plotter, 4-10

I

I-block format, 4-9

IDCF command, 5-73

ID command, 5-72

IDFREQ command, 5-74

IF ADJUST menu key, 2-9

IF INPUT, 2-42

IMAGE statement, 4-4

input attenuation, 5-22

input connectors
 CAL OUTPUT, 1-3
 IF INPUT, 1-3
 INPUT 50Ω, 1-3
 PROBE POWER, 1-3
input mixer, 2-9
instrument preset, 5-75
instrument state, 1-2, 2-21
instrument state control, 5-8
INT menu, 1-17
INTEN menu key, 2-57
intensity, 2-57
INT key, 2-36
IP command, 4-4, 5-75

J

J, 3-34
J1, 1-6
J2, 1-6
J3, 1-6
J4, 1-6
J5, 1-6, 2-53
J6, 1-6
J8, 1-7, 2-44
J9, 1-7

K

K

 annotation, 1-5
 frequency band, 3-34
keys, 1-8

L

LAST STATE menu key, 2-23
LG command, 5-78
LINE, 2-23, 2-30
LINEAR menu key, 2-9
line input voltage, 1-6
LINE menu key, 2-53
LN command, 5-80
LO and IF adjustments, 5-11
LOCK HARMONIC menu key, 2-38
LOCK ON OFF menu key, 2-38
LO FREQ menu key, 2-33
LOG dB DIV menu key, 2-8

M

M, 1-5
MAIN ROLLER menu key, 2-34
marker, 1-2, 2-12
 amplitude, 5-84
 commands, 5-8
 delta, 5-86
 delta to span, 5-105

frequency, 5-89
noise, 5-96
normal, 5-94
off, 5-98
priority, 2-61
query, 4-6
reciprocal of delta, 5-88
threshold, 5-100
time, 5-107
to center frequency, 5-85
to center frequency step size, 5-106
to minimum, 5-93
to reference level, 5-104

MARKER

 1/DELTA menu key, 2-13
 DELTA menu key, 2-13, 2-15, 2-19, 2-26, 2-28
 NEXT PEAK menu key, 2-16
 NORMAL menu key, 2-12, 2-19, 2-25, 2-28, 2-41

MARKER→CF menu key, 2-15, 2-20
MARKER→CF STEP menu key, 2-20
MARKER→REF LVL menu key, 2-20
Mass Memory Module, 2-32
MAX HOLD A menu key, 2-48
MAX HOLD B menu key, 2-49
maximum hold, 5-111
maximum input signal, 2-8
MAX MXR LEVEL menu key, 2-9, 2-45
MAX NO. VID AVGS menu key, 2-46
MBIAS command, 5-81
MEAS UNCAL, 2-6
basic measurement, 1-9
menus, 1-8
MINH command, 5-83
minimum hold, 5-83
mixer level, 5-109
mixer mode, 5-112
MKA command, 5-84
MKCF command, 5-85
MKD command, 5-86
MKDR command, 5-88
MKFC command, 5-90
MKF command, 5-89
MKFCR command, 5-91
MKMIN command, 5-93
MKN command, 5-94
MKNOISE command, 5-96
MKOFF command, 5-98
MKPK command, 5-99
MKPT command, 5-100
MKPX command, 5-102
MKR 1/Δ→CF menu key, 2-20
MKR 1/Δ→CF STEP menu key, 2-20
MKRL command, 5-104
MKRNOISE menu key, 2-16

MKRNOISE ON OFF menu key, 2-13
MKR→ menu, 1-18
MKR→ key, 2-19
MKR Δ→CF menu key, 2-20
MKR Δ→CF STEP menu key, 2-20
MKRΔ→SPAN menu key, 2-20
MKSP command, 5-105
MKSS command, 5-106
MKT command, 5-107
MKTRACK command, 5-108
ML command, 5-109
modulation, See Amplitude, frequency
MODULE key, 2-32
MXMH command, 5-111
MXRMODE command, 5-112

N

NEXT PEAK menu key, 2-26, 2-28, 2-41
NEXT PK LEFT menu key, 2-16
NEXT PK RIGHT menu key, 2-16
note

- 0 db input attenuation, 2-7
- amplitude modulation, 3-20
- band overlap, 1-10
- bias, 2-42
- frequency bands, 2-5
- frequency range, 1-1
- incidental AM on FM signal, 3-26
- reference level calibration, 1-14
- signal compression, 3-31
- sweep time vs. bandwidth, 3-19
- the EP command, 5-2
- warm-up time, 1-13

O

OFF key, 2-15
OFFSET ROLLER menu key, 2-34
ON menu, 1-18
ON key, 2-12
OP command, 5-113
operator entry, 5-10
Output, 5-113
output format commands, 5-10
output identification, 5-72
OUTPUT statement, 4-3

P

P1, 4-10
P1, P2, 2-55
P2, 4-10
peak excursion, 2-26, 5-102
PEAK EXCURSN menu key, 2-17
peak search, 5-99
PEAK SEARCH

key, 2-15
menu, 1-18
menu key, 2-20, 2-26, 2-28, 2-41
PEAK THRESHLD menu key, 2-17
plot
 commands, 5-8
 display, 5-114
 display origins, 5-115
 generating, 4-10
 making, 4-11
 requirements, 4-10
 scaling points, 4-10
 source, 5-116
PLOT command, 5-114
PLOT ANNOT menu key, 2-55
PLOT GRATICULE menu key, 2-55
PLOT menu key, 2-54
PLOT OPTIONS menu key, 2-55
PLOTORG, 4-13
PLOTORG command, 5-115
PLOT ORG DSP GRAT menu key, 2-55
PLOTSRC, 4-12
PLOTSRC command, 5-116
PLOT TRACE A menu key, 2-55
PLOT TRACE B menu key, 2-55
power bandwidth, 2-14
PP command, 5-118
PRESEL AUTO PK menu key, 2-37
preselector
 commands, 5-9
 DAC number, 5-121
 peak, 5-118
preselector data, 2-35
preselector peaking, 2-36
 current data table, 2-36
 factory data table, 2-36
 user data table, 2-36
PRESEL MAN ADJ menu key, 2-37
PRESET menu, 1-18
PRESET key, 2-21
print commands, 5-9
PRINT
 command, 5-119
PRINT menu key, 2-54
PRINT PLOT menu key, 2-54
program development, 4-4
programming techniques, 4-33
protect state, 5-122
PSDAC command, 5-121
PSTATE command, 5-122
pulsed RF
 center frequency, 3-28
 desensitization, 3-31
 measurement, 3-27
 peak pulse power, 3-31

- pulse mode, 3-27
- pulse repetition interval, 3-30
- pulse width, 3-29
- side lobe ratio, 3-28
- PWRBW command, 5-123
- PWR ON STATE menu key, 2-30

Q

- Q, 3-34

R

- R, 1-5
- RB command, 5-124
- RBR command, 5-126
- RBW SPAN menu key, 2-45
- RCLS command, 5-127
- RCLT command, 5-128
- REALIGN LO & IF menu key, 2-23
- rear panel, 1-6
- REAR PNL OUTPUT menu key, 2-44
- recall
 - state, 5-127
 - trace, 5-128
- RECALL
 - ERRORS menu key, 2-33
 - key, 2-32
 - menu, 1-19
 - PRSEL PK menu key, 2-35
 - STATE menu key, 2-32
 - TO TRA menu key, 2-33
 - TO TRB menu key, 2-33
- RECALL PWR ON menu key, 2-23
- Recommended Path, 5-2
- reference level, 5-130
 - calibration, 5-132
 - offset, 2-9
 - offset command, 5-133
- REF LVL CAL menu key, 2-9
- REF LVL menu key, 2-7
- REF LVL OFFSET menu key, 2-9
- remote operation
 - address, 4-2
 - equipment, 4-1
- Repeating Syntax Element, 5-2
- request service, 5-135
- RES BW AUTO MAN menu key, 2-46
- RES BW menu key, 2-46
- reserved words, 5-3
- Reserved Words, 5-2
- resolution bandwidth, 5-124
 - sequence, 3-16
 - shape factor, 3-17
 - signal resolution, 3-16
 - sweep time, 3-19
 - to span ratio, 5-126

- REV command, 5-129
- revision number, 5-129
- RLCAL command, 5-132
- RL command, 5-130
- ROFFSET command, 5-133
- RQS, 4-23
- RQS command, 5-135

S

- S, 1-5
- SAMPLER FREQ menu key, 2-34
- SAMPLER HARMONIC menu key, 2-34
- save
 - state, 5-137
 - trace, 5-138
- SAVE
 - key, 2-30
 - LOCK ON OFF menu key, 2-31
 - menu, 1-19
 - PRES PK menu key, 2-31
 - STATE menu key, 2-30
 - TRACE menu key, 2-31
- SAVES command, 5-137
- SAVET command, 5-138
- scale
 - linear, 2-9, 5-80
 - log, 2-8
 - logarithm, 5-78
- SCREEN TITLE menu key, 2-56
- Secondary Keywords, 5-2
- SER command, 5-139
- serial number, 5-139
- service diagnostics, 5-7
- service request, 5-9, 5-147
 - masking, 4-23
 - reading, 4-24
- service requests, 4-22
- SIG ID
 - AT MKR menu key, 2-40
 - ON OFF menu key, 2-41
 - CF menu key, 2-40
- SIGID, 5-73
- SIG ID AT MKR menu key, 2-37
- SIGID command, 5-140
- SIG ID ON OFF menu key, 2-37
- SIG ID→CF menu key, 2-37
- signal compression, 3-31
- signal connections, 1-3
- signal identification, 2-37, 3-34-35, 5-140
 - frequency, 5-74
 - to center frequency, 5-73
- SIGNAL IDENT menu key, 2-40
- signal track, 5-108
- SIG TRK menu key, 2-16

SIG TRK ON OFF menu key, 2-13
 SINGLE menu key, 2-44, 2-53
 SNGLS command, 4-4, 5-142
 span, 1-2
 limits, 2-3
 SPAN
 FULL menu key, 2-5
 key, 2-5
 LAST menu key, 2-6
 menu, 1-19
 WIDTH menu key, 2-5
 ZERO menu key, 2-5
 SP command, 5-143
 Special Numbers and Characters, 5-2
 SPOLL, 4-25
 SQUELCH command, 5-145
 SQUELCH menu key, 2-29
 SRQ command, 5-147
 SS command, 5-148
 START FREQ menu key, 2-3
 start frequency, 5-52
 status byte query, 5-152
 status register, 4-22
 STB, 4-24
 STB command, 5-152
 ST command, 5-150
 STOP FREQ menu key, 2-3
 stop frequency, 5-54
 sweep
 commands, 5-9
 continuous, 5-35
 output, 5-153
 single, 5-142
 time, 5-150
 SWEEP menu, 1-20
 SWEEP key, 2-43
 SWEEP TIME menu key, 2-6, 2-44
 SWPOUT command, 5-153
 SWP TIME AUTO MAN menu key, 2-44
 synchronization commands, 5-9
 syntax conventions, 5-2
 syntax elements, 5-5
 Syntax Elements, 5-2

T

T, 1-5
 take sweep, 5-164
 TDF command, 5-154
 Test and Adjustment Module, 2-32
 TH command, 5-156
 third-order intermodulation distortion
 definition, 3-4
 measurement, 3-4
 THRESHLD menu key, 2-56
 THRESHLD ON OFF menu key, 2-56

threshold, 5-156
 title, 3-8
 creating remotely, 4-7
 TITLE command, 5-158
 TM command, 5-160
 TRA, 4-15
 trace
 data format, 5-154
 data input/output, 5-162
 TRACE
 A menu key, 2-49
 B menu key, 2-48
 key, 2-48
 menu, 1-20
 trace A exchange trace B, 5-27
 TRACE ALIGN, 1-7, 2-34
 trace commands, 5-10
 trace data
 format M format, 4-20
 limits, 2-59
 transfer, 4-14
 transfer A block format, 4-18
 transfer B format, 4-16
 transfer conditions, 4-14
 transfer I block format, 4-19
 transfer P format, 4-15
 transfer requirements, 4-14
 transfer trace length, 4-14
 trace-data conversion, 4-17
 trace math, 2-49-50, 2-58-60, 4-27
 adding and subtracting in dBm, 4-27
 adding and subtracting in volts, 4-28
 data limits, 4-29
 trace A minus trace B, 5-16
 trace A minus trace B plus display line, 5-18
 trace A plus trace B, 5-21
 trace B minus display line, 5-29
 trace power bandwidth, 5-123
 trace window, 5-165
 TRA command, 5-162
 TRANSFER ROLLER menu key, 2-34
 TRB, 4-15
 TRIG menu, 1-20
 trigger
 commands, 5-9
 external, 2-53
 free run, 2-53
 mode, 5-160
 video, 2-53
 TRIG key, 2-53
 TS command, 5-164
 TWINDOW command, 5-165

U

U, 3-34
UNITS menu key, 2-10
USING statement, 4-3

V

V, 3-34
variables, 4-3
VAVG command, 5-166
VB command, 5-168
VBR command, 5-170
VBW RBW menu key, 2-45
VID AVG ON OFF menu key, 2-46
video
 average, 5-166
 bandwidth, 5-168
 bandwidth to resolution bandwidth ratio, 5-170
 trigger level, 5-174
VIDEO BW AUTO MAN menu key, 2-46
VIDEO BW menu key, 2-46
VIDEO menu key, 2-53
view trace, 5-171

VIEW command, 5-171

VIEW A menu key, 2-48

VIEW B menu key, 2-49

vol, 1-2

VOL command, 5-172

VOLTS menu key, 2-10

volume, 5-172

VOLUME menu key, 2-29

VTL command, 5-174

W

W, 3-34

WATTS menu key, 2-10

X

X, 1-5

X POSN, 1-7, 2-34

Y

Y, 3-34

Y POSN, 1-7, 2-34



HP MANUAL PART NUMBER 08562-90086

PRINTED IN USA

<http://www.voilelec.com>